

# ***Reinhold Environmental Ltd.***

---



***2007 APC Round Table & Expo  
Presentation***

---

***July 8-10, 2007  
Chattanooga, TN  
Hosted by TVA***

# Absorber Pumps

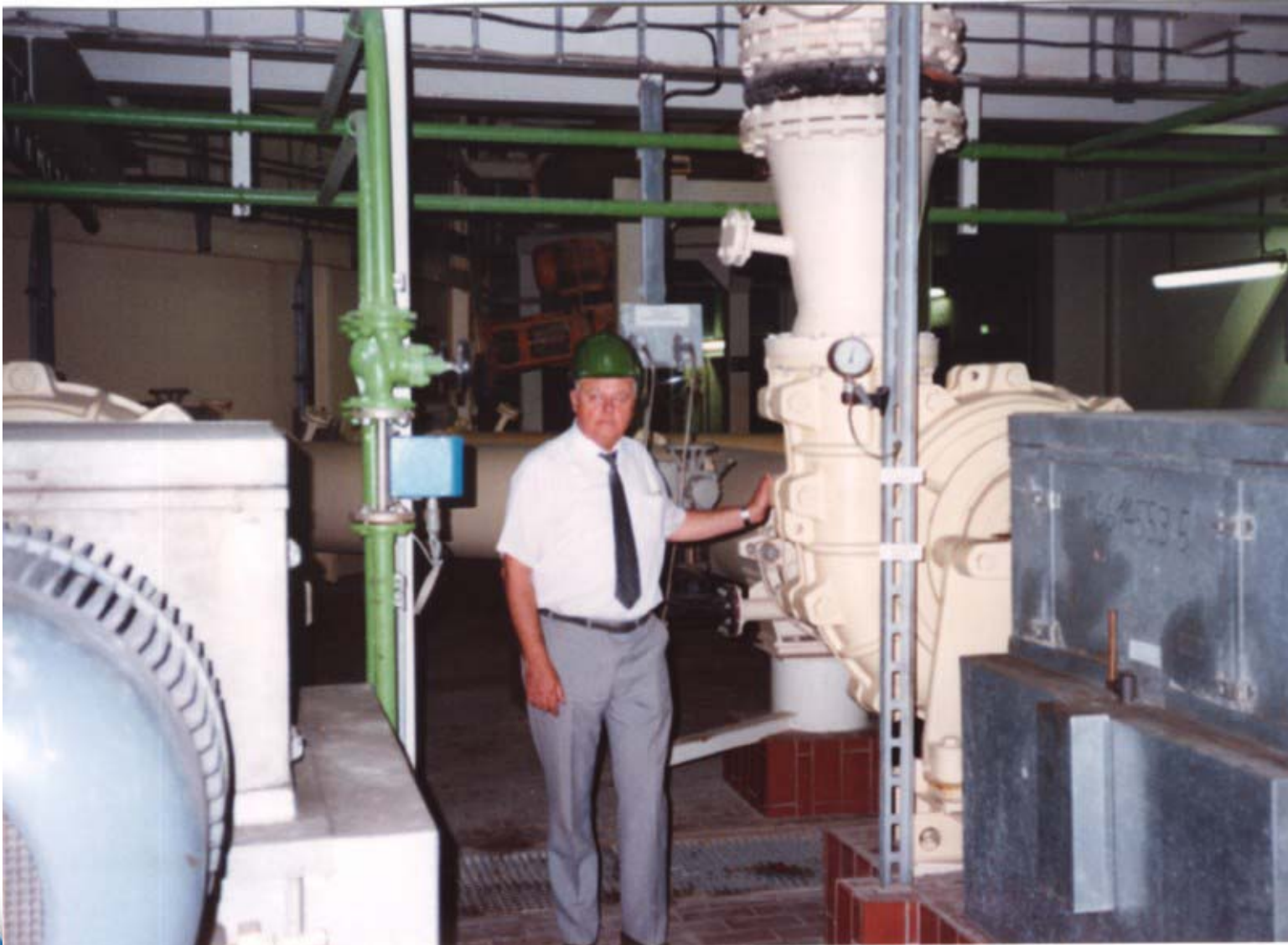

Source: Weir Pumps

**8,000 gpm**



# Absorber Pumps



**70,000 gpm**

**Source: Weir Pumps**



# Absorber Pump with FRP Pipe (Note Supports)



# *Absorber Mixers (Agitators)*



**Source:**  
***Babcock Power Inc.***

# ***Mixer Mounted on Absorber Shell***



***Source: Alstom Unit at Centralia***

# Absorber Mixer Design

## Installation Angle

installation angle  $\beta = f(d_1, d_2, n_2, q, \text{quantity of agitators})$

$\beta = 0$   
deposits at  
the vessel  
wall

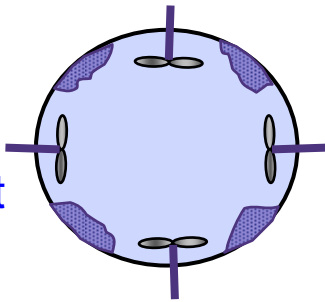

$\beta = \text{too large}$   
deposits in  
the centre

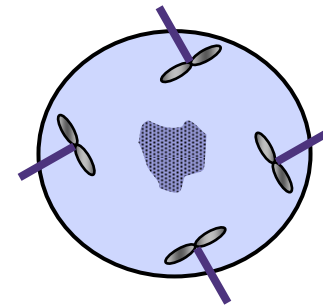

$\beta = \text{optimal}$   
no deposits

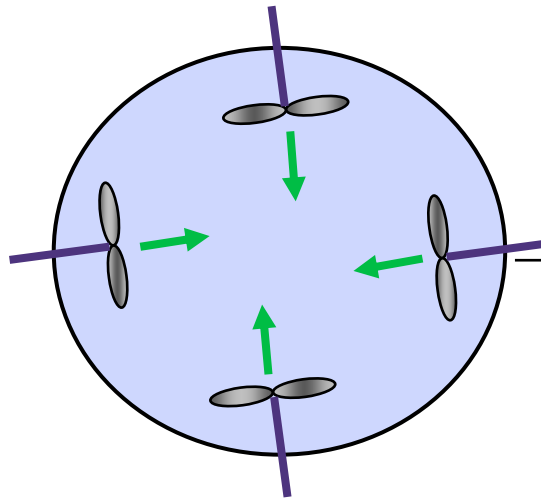

**Source:**  
**Ekato**

# ***Mixer Blade Erosion (Two-Year Outage Inspection)***



# ***Absorber Tank Access Door***

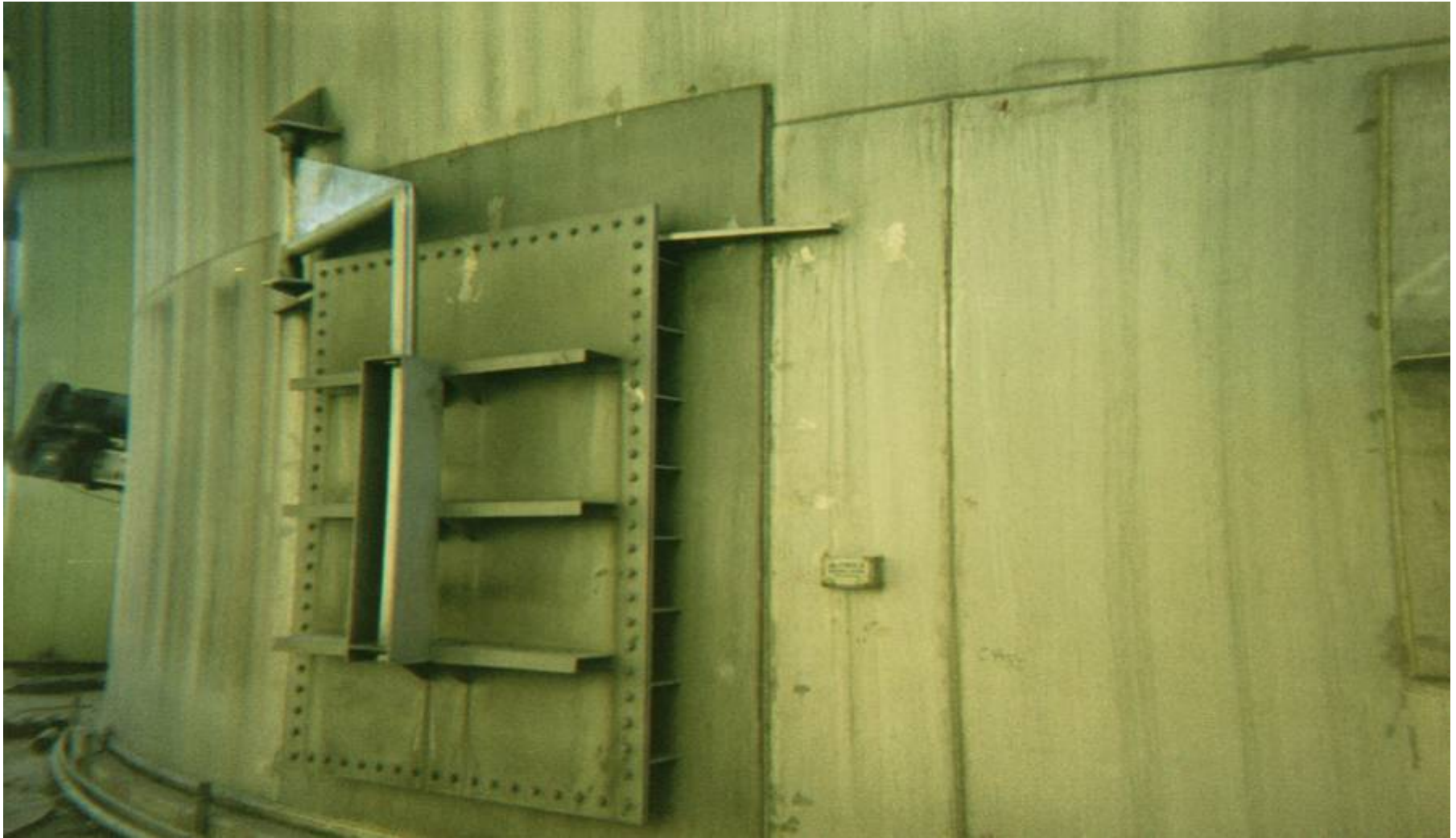

***Source: Alstom Unit at Centralia***

# Alloy Construction Flexibility

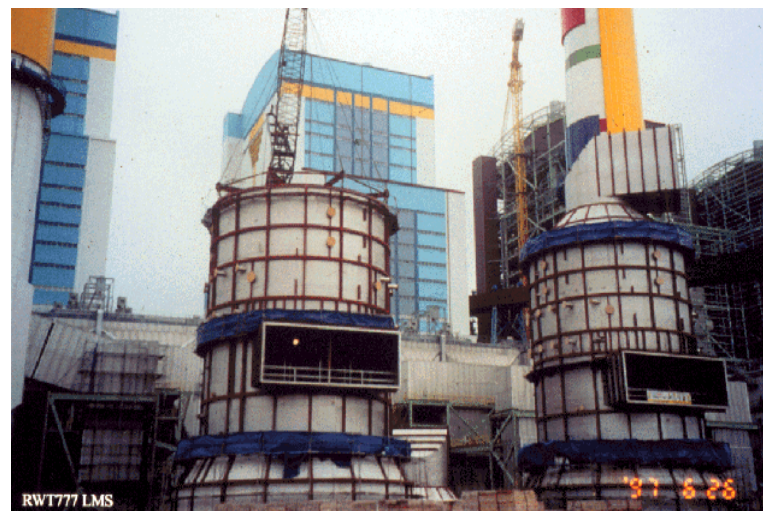

***Korea Electric Power (10 x 500 MW)***



# Stebbins Absorber Tower



# ***Stebbins Tile Lining***



# *Rubber Lining Application*



# *Flakeglass Lining Application*

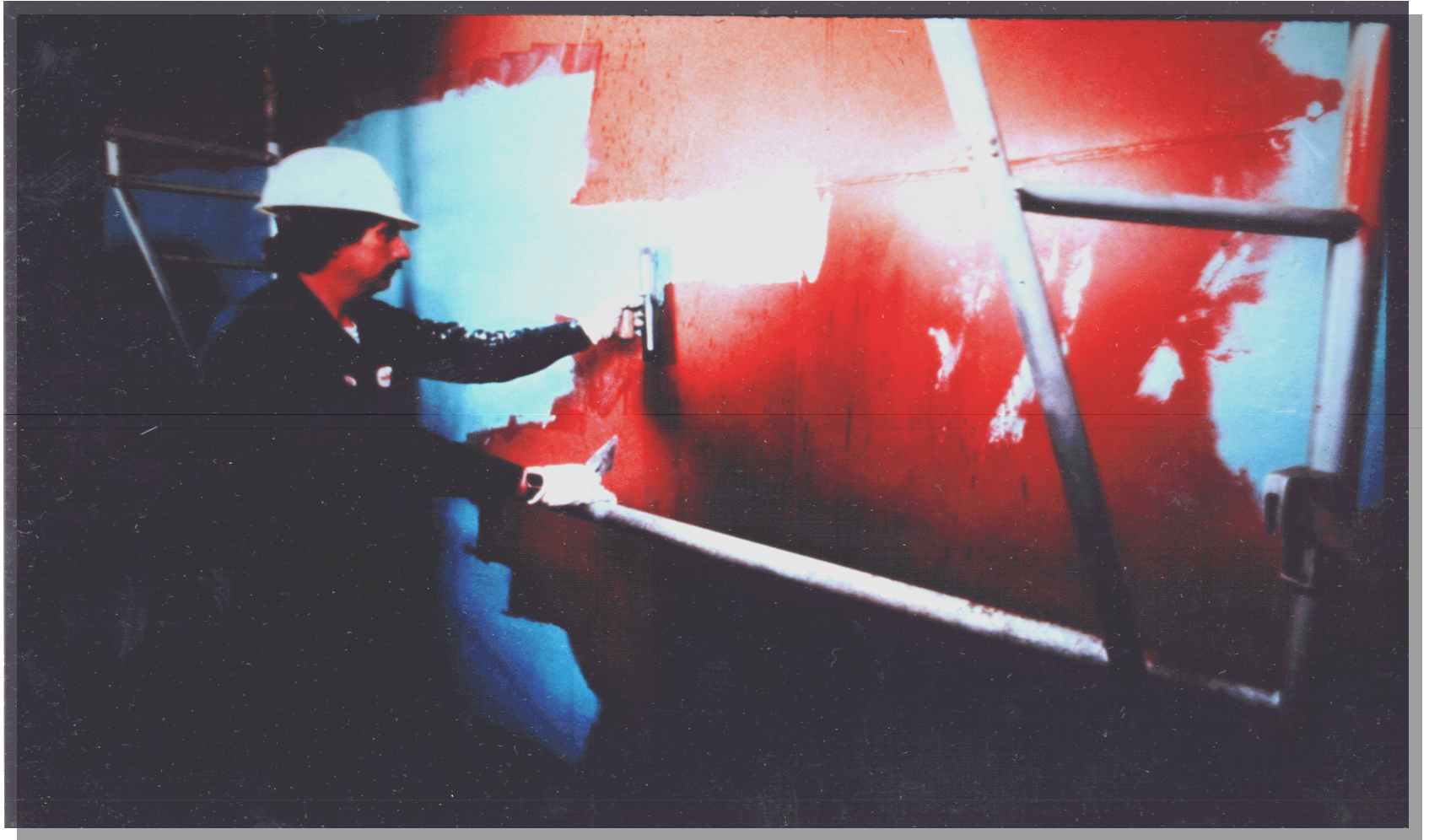

# ***Workshop Outline***

## **1. Wet FGD Process Description, Equipment, Configuration, Materials**

**What's the issue & progress**

**Overview of major types of utility FGD systems**

**General description of wet limestone forced oxidized (LSFO) system**

**Basic types & configurations of commercially available LSFO FGD technology**

**Absorber Configuration, Equipment, Materials**

**Forced Oxidation / Dewatering, Milling System**



# Absorber Tower Subsystems

- **Forced oxidation**

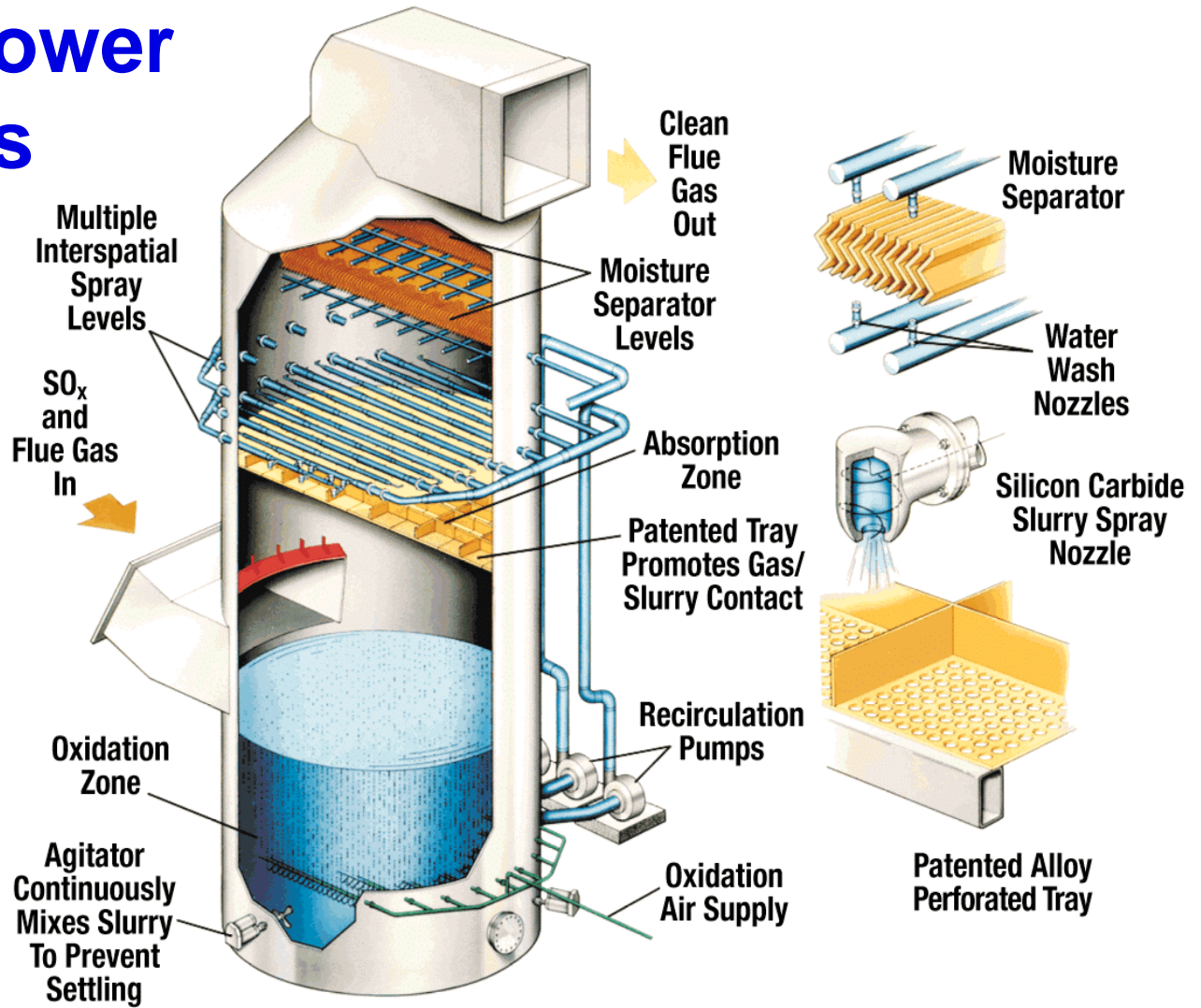

# Yesterday: Natural Oxidation

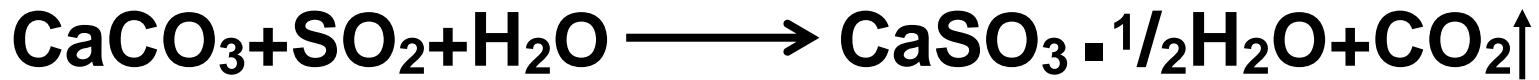

(Gas-to-Sorbent Reaction)

Calcium Carbonate - active  
ingredient in limestone

Calcium Sulfite

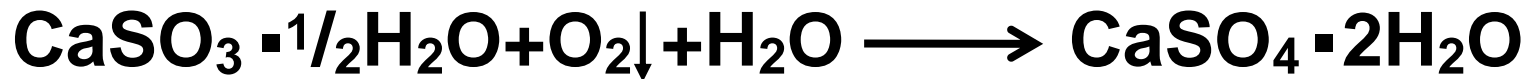

20-50% Complete (Natural Oxidation Reaction)

Calcium Sulfate or Gypsum

# Today: Forced Oxidation

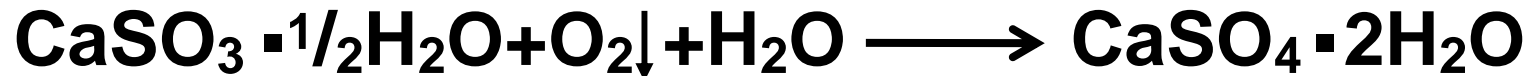

~100% Complete (Forced Oxidation Reaction)

Calcium Sulfate or Gypsum

# Today: or Inhibited Oxidation



# *Today: Gypsum Production*



# Filter Cake Solids - 75x

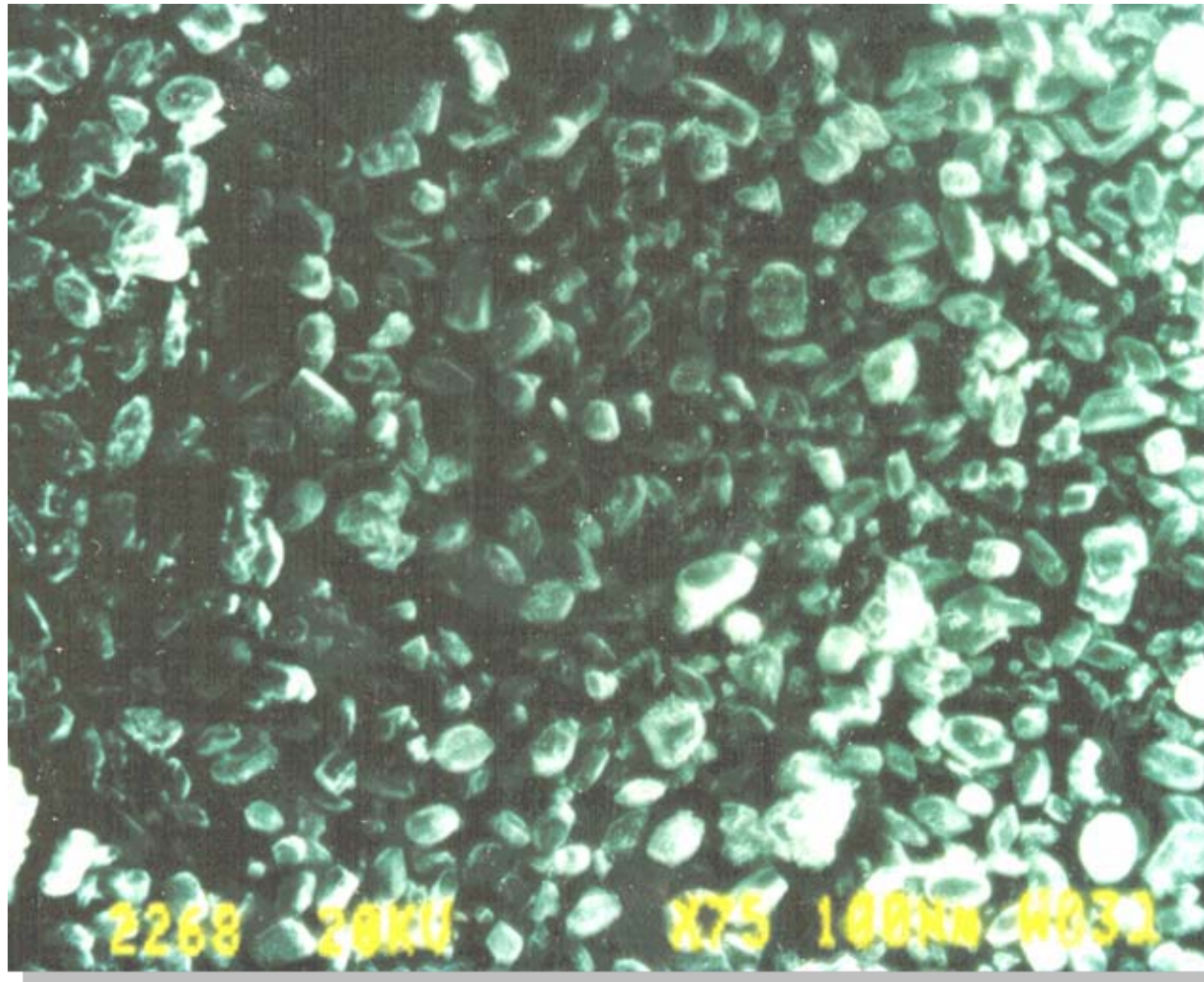



# Forced Oxidation - Sparge Header

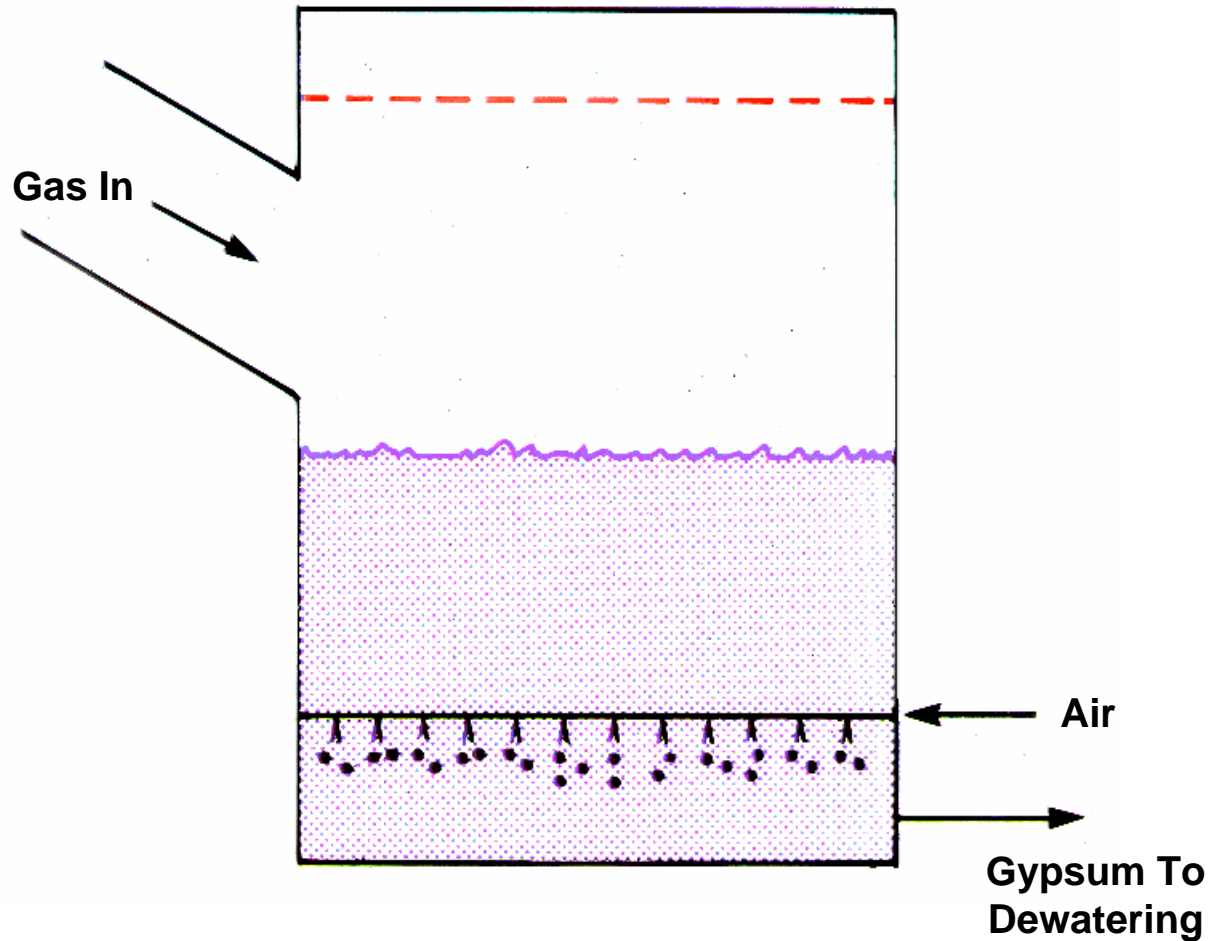

# *Forced Oxidation Agitator with Lance*

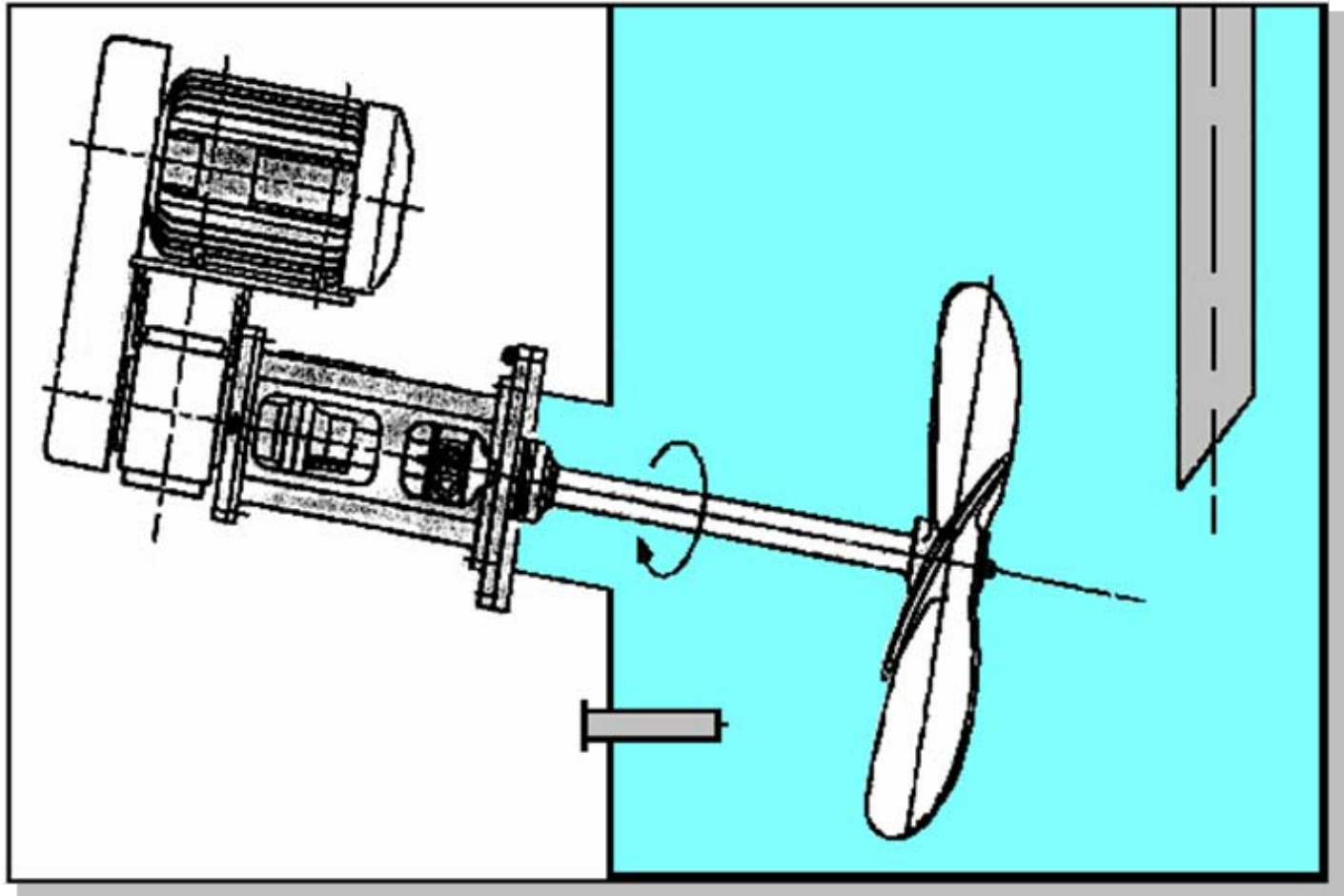

# *Lance Oxidation*



# *Agitator with Oxidation Lance*



# *Oxidation Air Compressor*



# Dewatering System

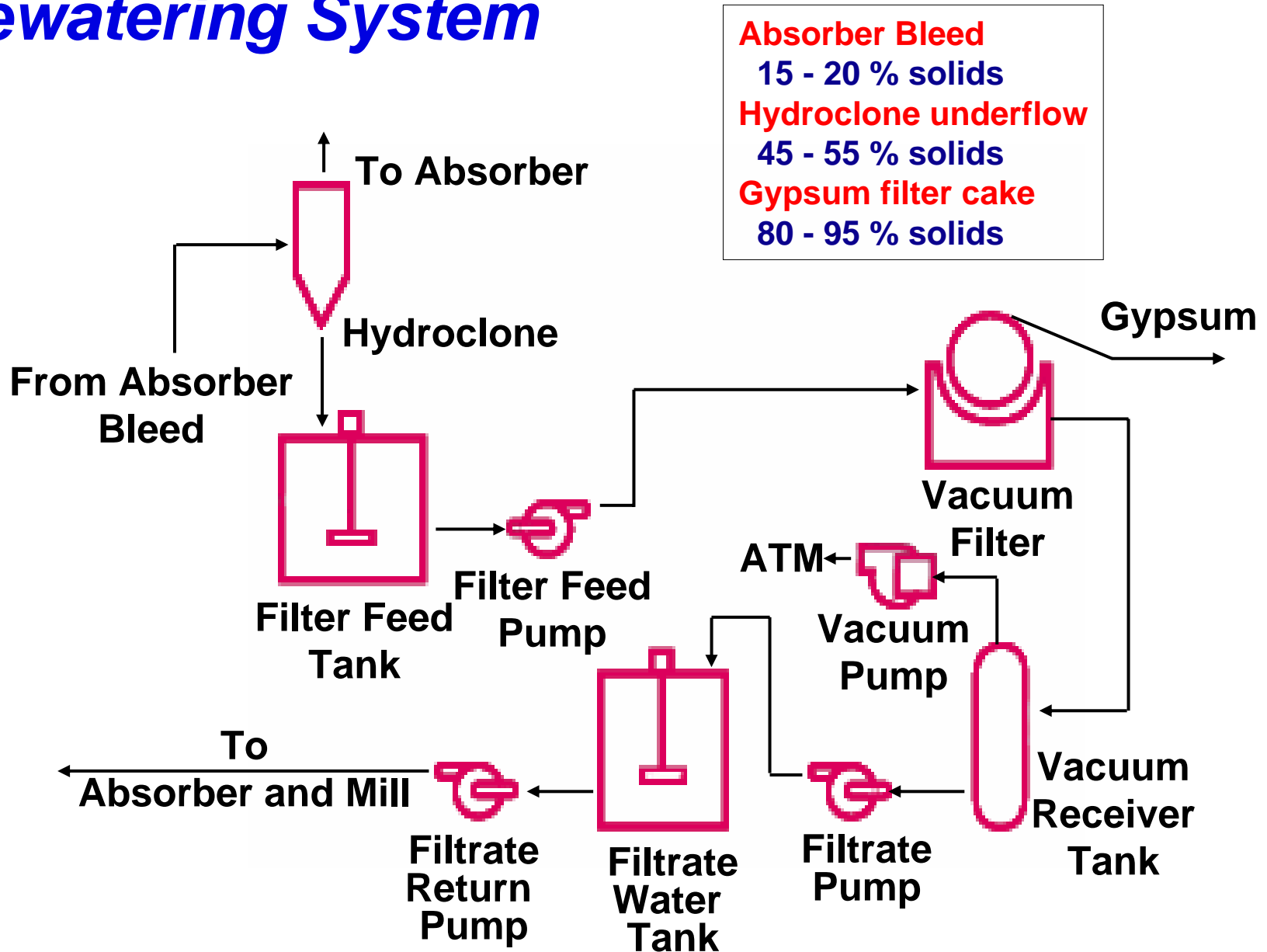

# Primary Dewatering Hydroclones

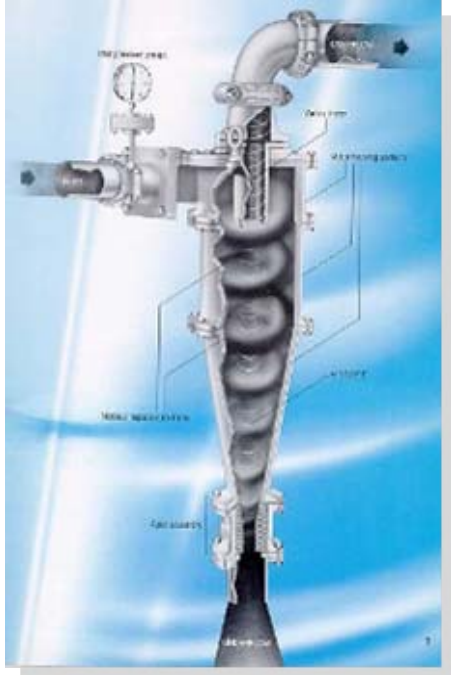

**Primary Hydroclone Bank**



**Secondary (Purge) Hydroclone Bank**



# Secondary Dewatering by Drum Filter...



# *Drum Filter Cake Discharge*



# *An Option for Secondary Dewatering: Belt Filter*



## *...or Centrifuge (Basket Type)*



# Reagent (Limestone) Preparation System

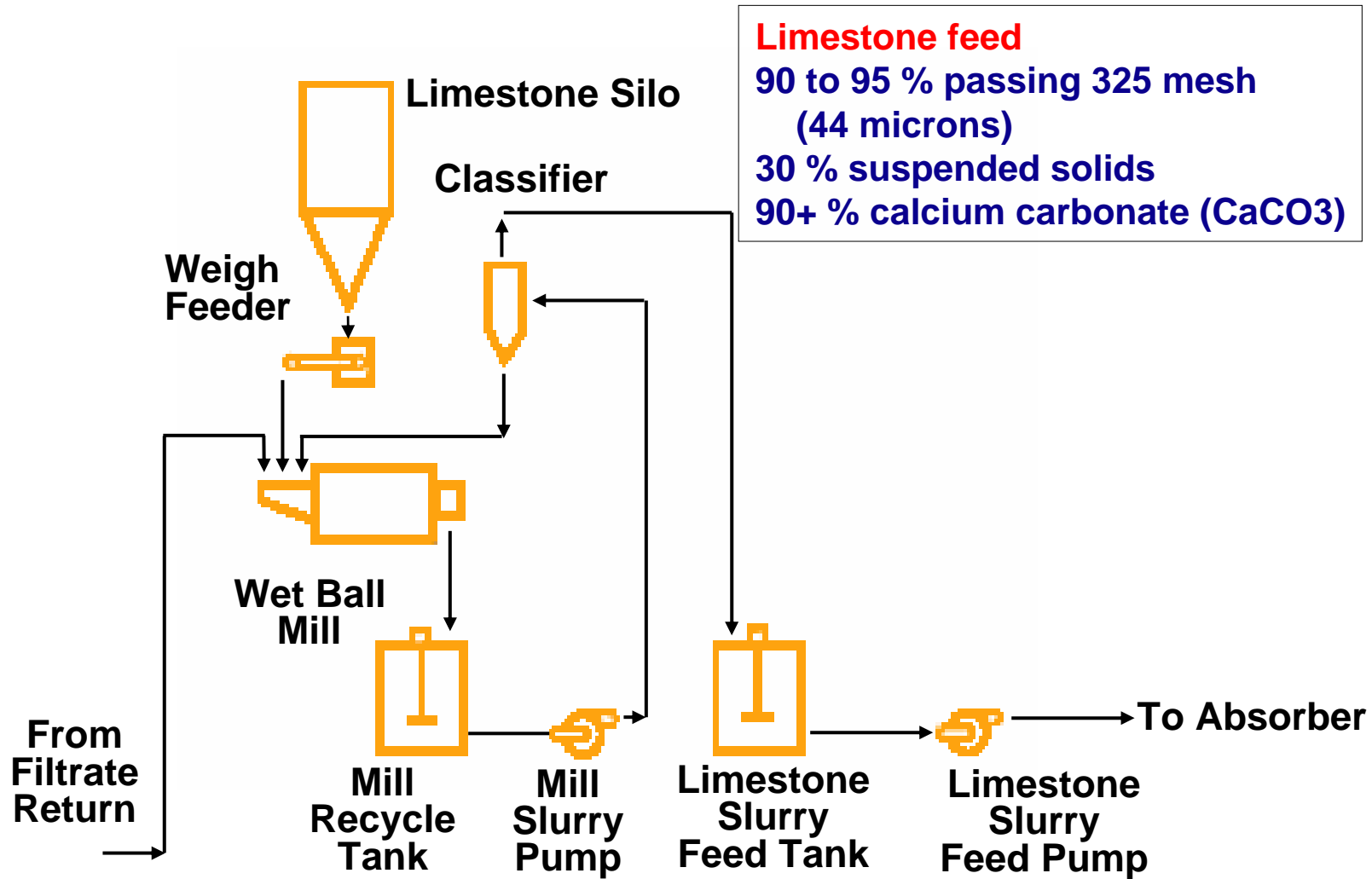

# *Horizontal Ball Mills*



# An Option: Vertimills



**~40 TPH max**  
**Feed size ¼" max**  
**Pre-crusher Req'd**





***Thank You!***



# ***Workshop Outline***

- 1. Wet FGD Process Description, Equipment, Configuration, Materials**
- 2. Chemistry Overview, Effect of Key Process Variables, Process Problems – Identify and Correct, Optimization of System Performance**
- 3. Equipment Operation and Maintenance**
- 4. Panel Discussion**



# ***Workshop Outline***

- 1. Wet FGD Process Description, Equipment, Configuration, Materials**
- 2. Chemistry Overview, Effect of Key Process Variables, Process Problems – Identify and Correct, Optimization of System Performance**
- 3. Equipment Operation and Maintenance**
- 4. Panel Discussion**



# ***Workshop Outline***

- 1. Wet FGD Process Description, Equipment, Configuration, Materials**
- 2. Chemistry Overview, Effect of Key Process Variables, Process Problems – Identify and Correct, Optimization of System Performance**
- 3. Equipment Operation and Maintenance**
- 4. Panel Discussion**

